

# WINDSOR PARK AT ABACOA - PLAT NO. 4

BEING A REPLAT OF LOTS 28 THROUGH 31, LOTS 72 THROUGH 75 AND LOTS 110 THROUGH 123, AS SHOWN ON THE PLAT OF WINDSOR PARK AT ABACOA - PLAT NO. 1, AS RECORDED IN PLAT BOOK 114, PAGES 135 THROUGH 142, AND A REPLAT OF LOTS 274 THROUGH 281, LOTS 317 THROUGH 324, LOTS 363 THROUGH 380 AND TRACT "OST-11", AS SHOWN ON THE PLAT OF WINDSOR PARK AT ABACOA - PLAT NO. 3, AS RECORDED IN PLAT BOOK 117, PAGES 167 THROUGH 173, PUBLIC RECORDS OF PALM BEACH COUNTY, FLORIDA LYING IN SECTION 14, TOWNSHIP 41 SOUTH, RANGE 42 EAST, TOWN OF JUPITER, PALM BEACH COUNTY, FLORIDA

JANUARY 2015

SHEET 4 OF 5

82

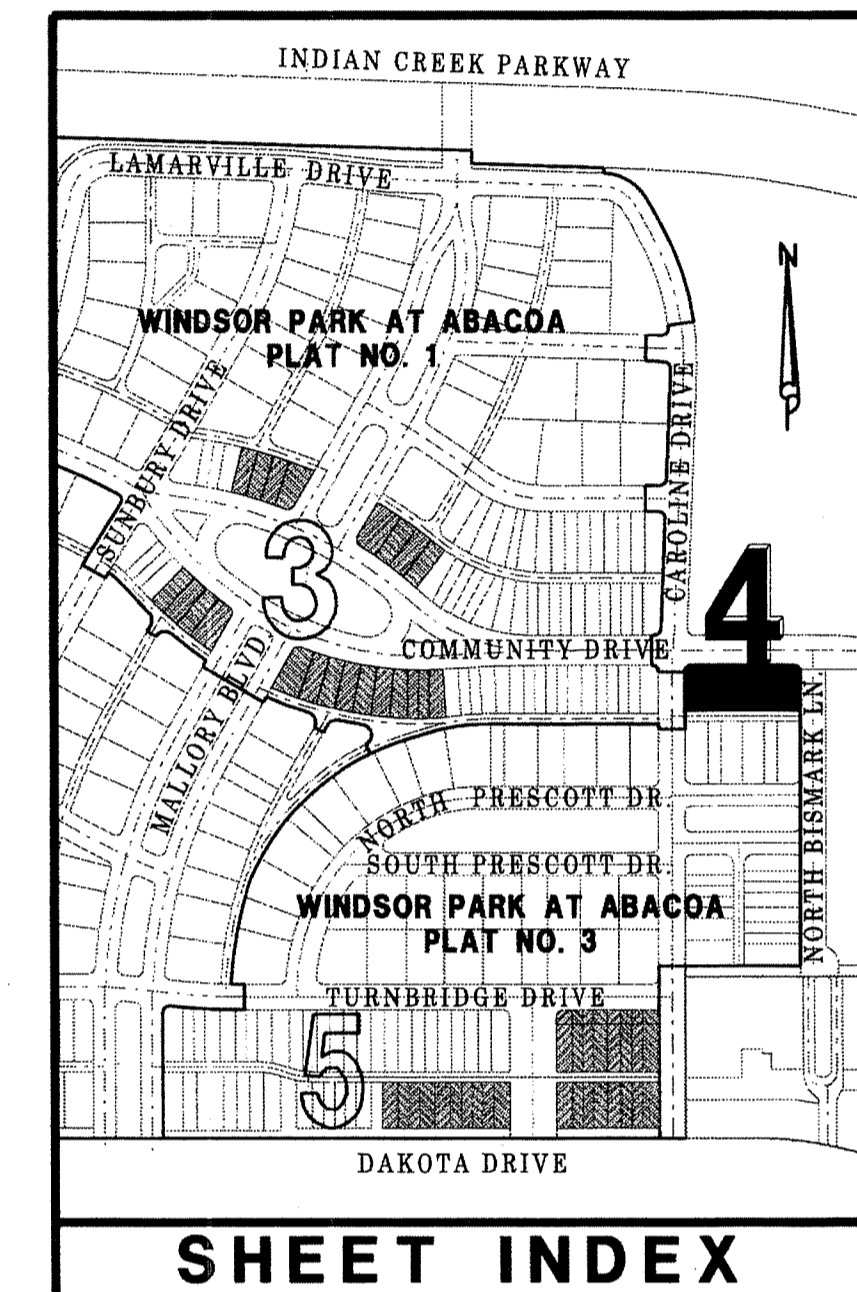
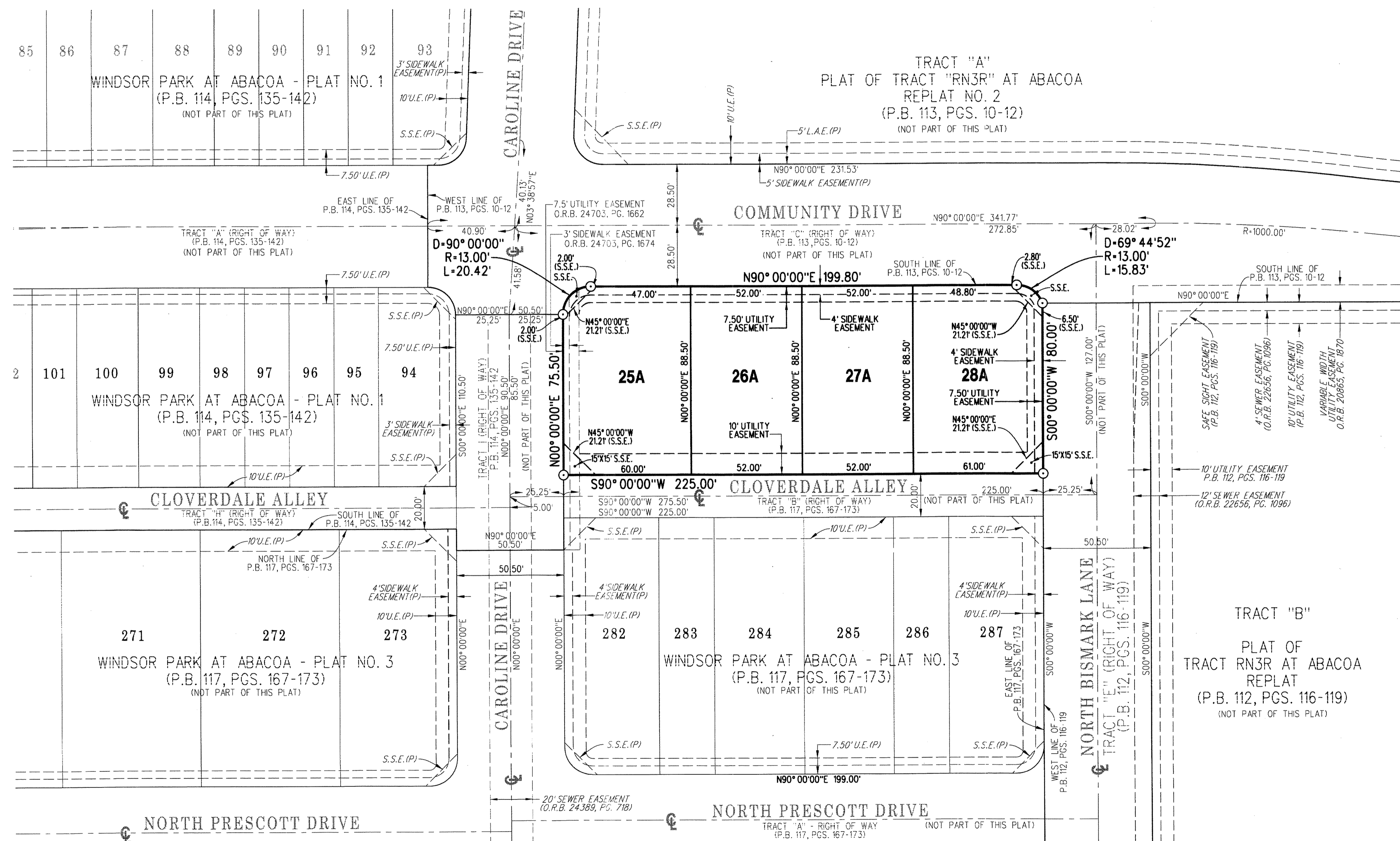
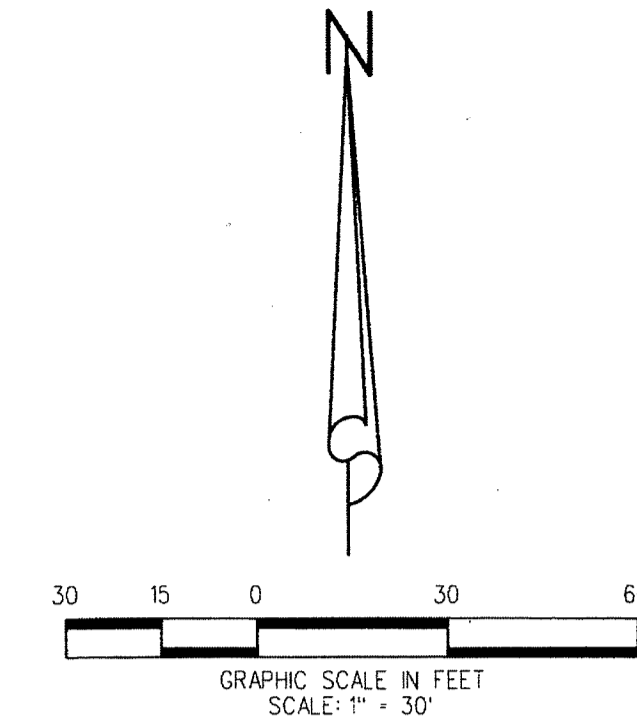

### ABBREVIATIONS:

- CB = CHORD BEARING
- CL = CHORD LENGTH
- D = DELTA
- D.E. = DRAINAGE EASEMENT
- F.P.L. = FLORIDA POWER & LIGHT
- L = ARC LENGTH
- L.A.E. = LIMITED ACCESS EASEMENT
- O.R.B. = OFFICIAL RECORD BOOK
- N.E. = NORTHEAST
- N.W. = NORTHWEST
- (P) = AS SHOWN ON P.B. 114 PGS. 135-142
- P.C.P. = PERMANENT CONTROL POINT
- P.B. = PLAT BOOK
- P.D.E. = PUBLIC DRAINAGE EASEMENT
- PG. = PAGE
- P.R.M. = PERMANENT REFERENCE MONUMENT
- P.S.M. = PROFESSIONAL SURVEYOR AND MAPPER
- R = RADIUS
- R.W.L.E. = RAW WATER LINE EASEMENT
- S.E. = SOUTHEAST
- S.S.E. = SAFE SIGHT EASEMENT
- S.W. = SOUTHWEST
- U.E. = UTILITY EASEMENT

### LEGEND:

- ☐ = DENOTES PERMANENT REFERENCE MONUMENT (P.R.M.) SET 4"x4" CONCRETE MONUMENT WITH DISK STAMPED "PRM LB4431" UNLESS OTHERWISE NOTED
- ⊙ = DENOTES PERMANENT REFERENCE MONUMENT (P.R.M.) SET MAG NAIL & DISK STAMPED "PRM LB4431" UNLESS OTHERWISE NOTED
- ⊕ = DENOTES CENTERLINE OF RIGHT OF WAY

**LIDBERG LAND SURVEYING, INC.**  
 675 West Indiantown Road, Suite 200, Jupiter, Florida 33458 TEL. 561-746-8454

CAD. K:\JUST \ 144142 \ WINDSOR \ 14-070-306 \ 14-070-306.DGN			
REF.			
FLD. AM.	FB. PG.	JOB 14-070-306	
OFF. CASASUS	671 663	1, 2 23, 32	DATE JANUARY 2015
CKD. D.C.L.	SHEET 4 OF 5	DWG. 014-070P	